

TWO POINT PERSPECTIVE - STEP BY STEP

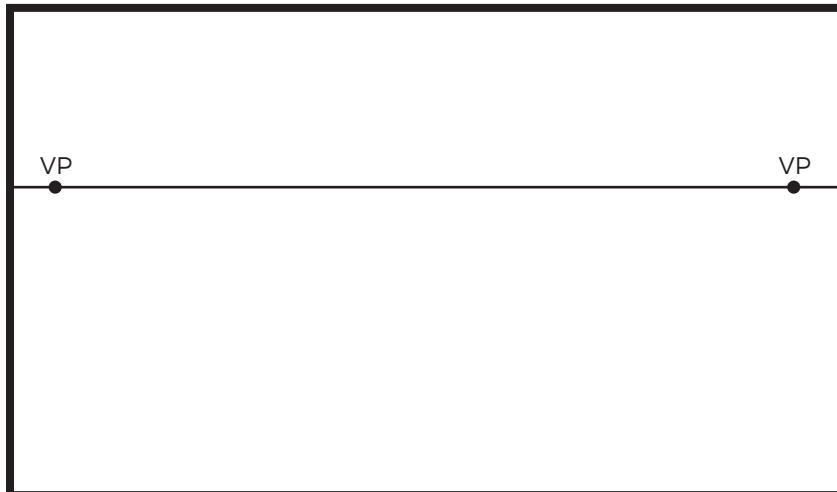

VP VP

Begin by drawing the horizon line and establishing the vanishing points. The vanishing points should be at the ends of the image.

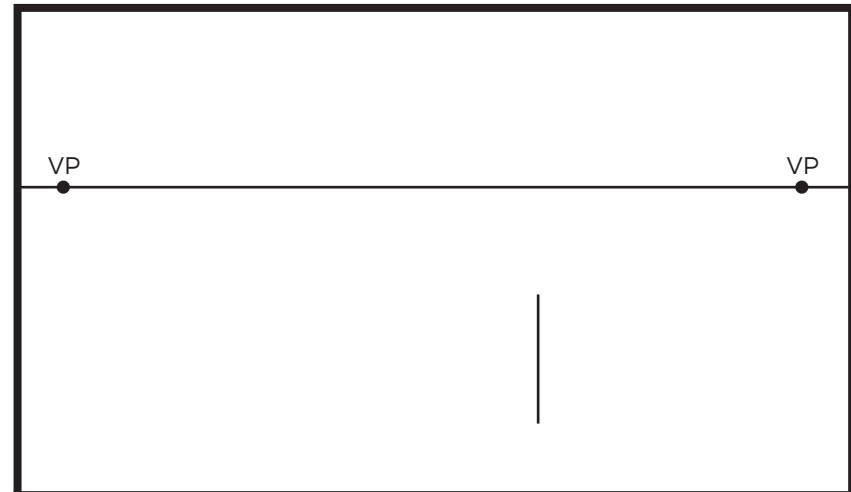

VP VP

Draw the corner of the box that is closest to you.

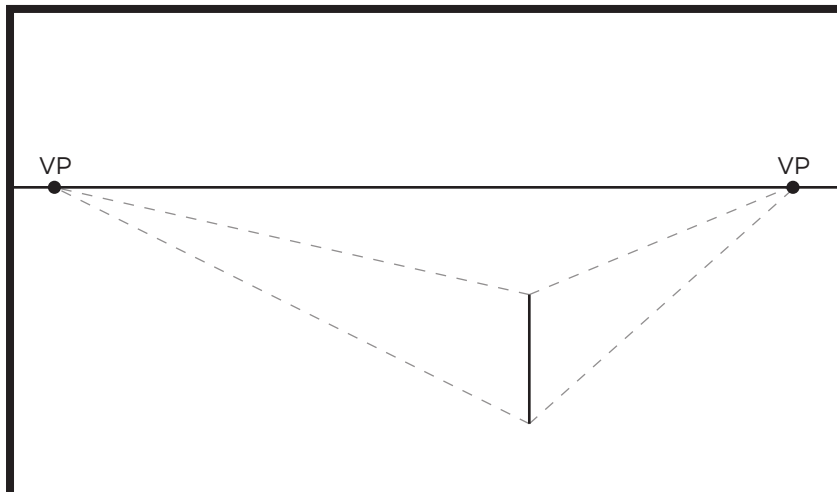

VP VP

Draw guidelines (orthogonals) from the top and bottom of the line to the vanishing points.

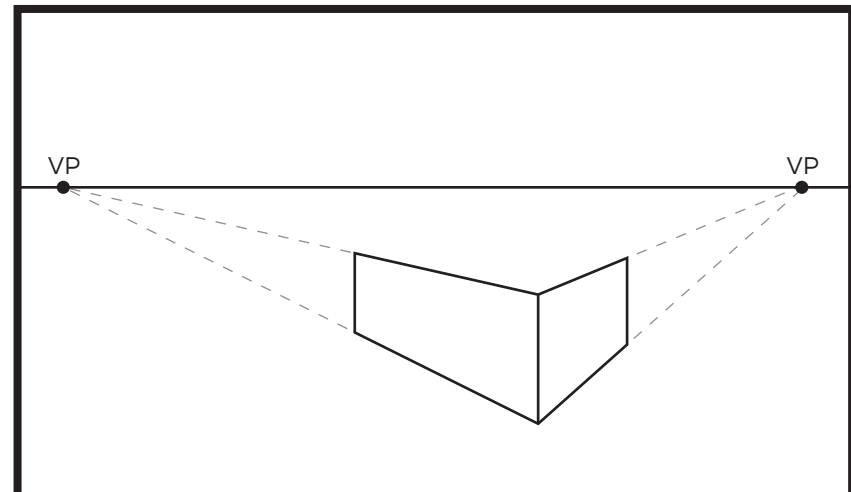

VP VP

Define the length and width of the box.

TWO POINT PERSPECTIVE - STEP BY STEP

